

ACCUWEIGH SEMI-PIT WEIGHBRIDGES

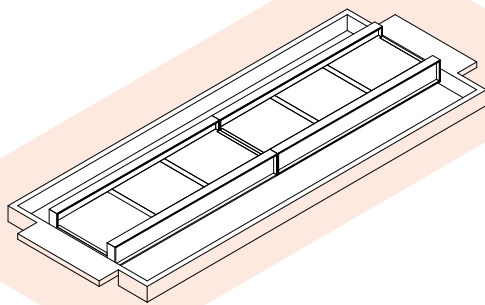

ISOMETRIC VIEW



FEATURES

- Steel Cross-Sections at Approximately 3m Spacings
- Designed for Minimal Concrete Cracking
- Engineering Report on Design Available
- Designed for Long-Term Performance
- Available in Standard 3m or 3.5m Widths
- Custom Widths Available
- Available in Kit Form, If Required
- Fully Hot-Dipped Galvanised



Chain of Responsibility
Solutions Providers

ACCUWEIGH



BY DIVERSECO

Australian-made, high-quality,
and precise weighing solutions.

- Australia's Largest Weighbridge Supplier - 100+ Weighbridges Sold Each Year
- A True National Company with Branches and Service Centres in All States
- 100% Australian-Owned and Operated Company, Profits Stay in Australia
- ISO 9001 Company Ensuring a Quality Product and Professional Service
- Experienced Weighbridge Service Crews in All States
- Trade-Approved, Designed for Australia's Harsh Environment
- Proven Design Over Many Installations

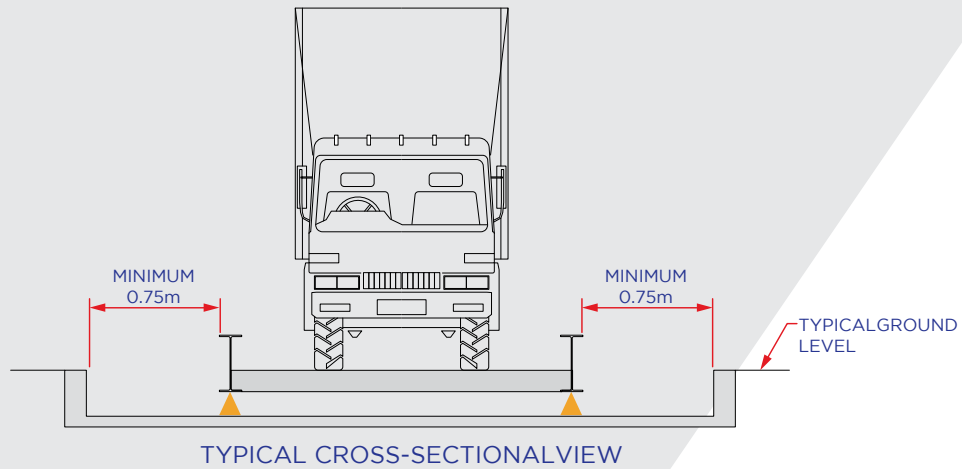

DESIGNS FORMAT ALTERNATIVES

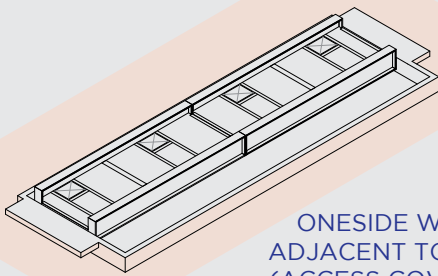

ONESIDE WALL
ADJACENT TO DECK
(ACCESS COVERS IN
DECK)

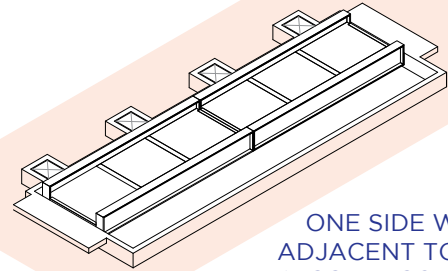

ONE SIDE WALL
ADJACENT TO DECK
(ACCESS COVERS IN
FOUNDATION)

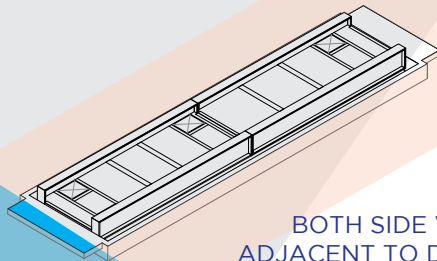

BOTH SIDE WALLS
ADJACENT TO DECK (MAIN
BEAMS PARTIALLY ABOVE
GROUND LEVEL)

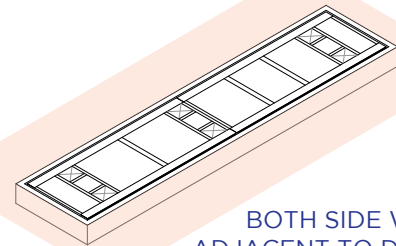

BOTH SIDE WALLS
ADJACENT TO DECK (MAIN
BEAMS BELOW GROUND
LEVEL)

All Branches T: 1300 069 970
 NSW (Sydney) T: (02) 9728 4877
 VIC (Melbourne South) T: (03) 9548 5512
 VIC (Melbourne North) T: (03) 9357 7470
 QLD (Brisbane North & South) T: (07) 3265 5520
 WA (Perth) T: (08) 9259 5535
 SA (Adelaide) T: (08) 8447 5011
 New Zealand (Auckland) T: +64 9 951 9685

diverseco.com.au

Diverseco
 Measurement & Automation

