

LP600™ Wheel Load Scales

Low-Profile, Lightweight Digital Wheel Load Scales



CERTIFIED



The Axle Weighing Specialist



Maximize Legal Payloads & Reduce Maintenance Due to Overload Stress on Equipment

Starting at a scale pad weight of 45 lb (21 kg), with a profile of just 1.5" (38 mm), the LP600™ Low-Profile Wheel Load Scale weighs loads up to 30,000 lb (15,000 kg) with an accuracy of $\pm 1\%$. Progressive solar charging technology allows the commercially available AA rechargeable batteries to be powered for up to one year with daytime, outdoor use.

Fully integrated RFX® Wireless Weighing Technology makes it possible to sequentially couple and number scales in a series for total weight and scales can be linked to a multitude of Intercomp weighing indicators. For customers whose local regulations prevent the use of wireless communications, radios can be disabled or Intercomp offers a full line of hard-wired alternatives.

LP600™ LOW-PROFILE WHEEL LOAD SCALES



NTEP/OIML Certified
Models Available

Accuracy of $\pm 1\%$ of Reading

Available in System Capacities
to 60,000 lb (30,000 kg)

Large LCD Display with
Backlight for Easy Readings
from Scales



Low-Profile Height of Just 1.5" (38 mm)

Rugged, Lightweight Aluminum
Construction Built to Withstand Heavy
Use; Ideal for Unimproved Surfaces

Solar Power Provides up to One Year of
Battery Life with Daytime, Outdoor Use
(up to 250 hours without Solar Power,
batteries included)

Integrated Indicator with Comprehensive
Push Button Controls Include:
On/Off, Local/Total, Zero & Print/Accum

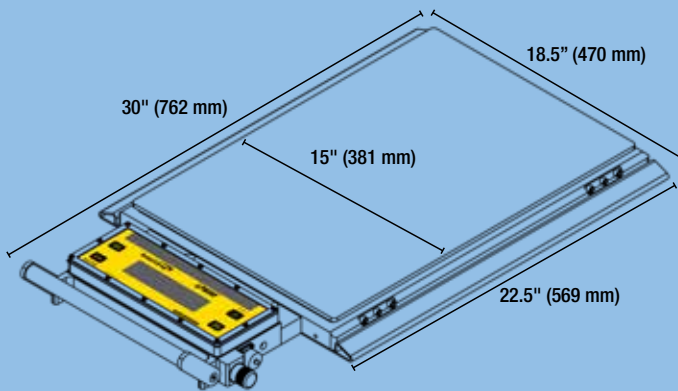

Compatible with these Intercomp Devices (Sold Separately)



HH™ Series Weighing Indicators



PT20™ Weighing CPU



IntercompWeigh™ Software



iVehicleWeigh™ Software



Displays & Printers

E: enquiries@diverseco.com.au

Ph: 1300 069 970

diverseco.com.au

