

Food X-ray Inspection

DYLOG[®]

HITECH

DYMOND



DYMOND SIDE VIEW MACHINE

The use of advanced components and an attentive, innovative and compact design, together with a high-performance and intuitive software allows Dymond machines to be fit for the ever higher standards set by food and pharmaceutical companies.

ADVANTAGES OF X-RAY INSPECTION

This is a **non-destructive analysis**, which, without altering the chemical composition or the organoleptic properties of the products, detects contaminants inside them (in any type of container or package) and verifies their wholeness and conformity. Contaminants having a density higher than the density of the inspected products (metals, glass, highly calcified bones, stones, shells, ceramics, PVC, Viton®) will no longer be a problem.

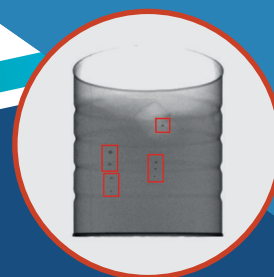

X-RAY POWER

500 W

POINT OF VIEW

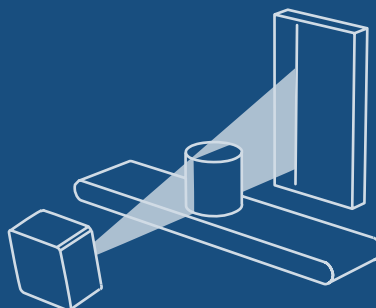

PRODUCTS



Hardware

The Dymond S is the result of years of development aimed to get a **simple and versatile inspection equipment** tailored to rigid products (glass jars, bottles, metal cans, brickpacks).

The **air cooling system** allows the machine to work in a wide range of temperature, without the need of an external water cooling system normally used with more powerful machines.

The Dymond S **can be installed on an existing straight conveyor**, with a quick and simple alignment procedure, thanks to the new numbered reference lines system.

Thanks to an innovative design philosophy, **all the main components are accessible and replaceable with ease**, as all internal surfaces are accessible and washable.

With the Dymond S, Dylog can offer a **really Plug&Play inspection solutions** for products in rigid container, keeping nonetheless top-notch performance levels.

Software

The Dylog contaminant detection software ensures a high performance level; thanks to new filtering technology and parallel elaboration, **the X-ray images are almost noiseless** with a high contrast level even at high product speed.

The innovative hardware design is coupled with an entirely new software interface for the Dymond S, that combines user friendliness with a complete set of functions, the result of over 20 years of experience in the food and pharmaceutical industries.

Sophisticated algorithms constantly refined provide excellent performances even when compared to systems with higher power.

The machine can be controlled from remote and features a 5-level password security system allowing to track the activity of each operator, logging in with a unique password.

Production and usage data are redundantly stored to grant top-notch level security, while the data accessibility is granted by easy to read automatic reports.

The system is **compatible with the strictest control protocols** implemented by the food industry largest companies.

Technical Features

Power	500 W
Detector resolution	0.8 or 0.4 mm
Conveyor belt speed	Up to 90 m/min
Conveyor height	800-1100 mm
Minimum distance between products	10 mm
Curtains	Optionals – lead-free
Safety switch / interlock	SIL 3 Category IV PLe, magnetic
HMI	15" LCD – touch screen
Operating temperature	5–38 °C
Relative humidity	20%–90% (non-condensing)
Power supply	230 VAC ±10% (standard) single-phase
Compressed air	5.5–6.9 bar
Cooling	Air conditioner Nema 4X 1100W
Radiation protection	FDA CFR 21 part 1020.40
International Protection Rating (IP)	IP65 (Nema 4X air conditioner)
Connectivity Options	Ethernet available with communication protocols: Modbus TCP (standard), OPC-DA, OPC-UA, XML messages on TCP, others on request
Production data trail	Complete records on parameters, users and products

Dimensions

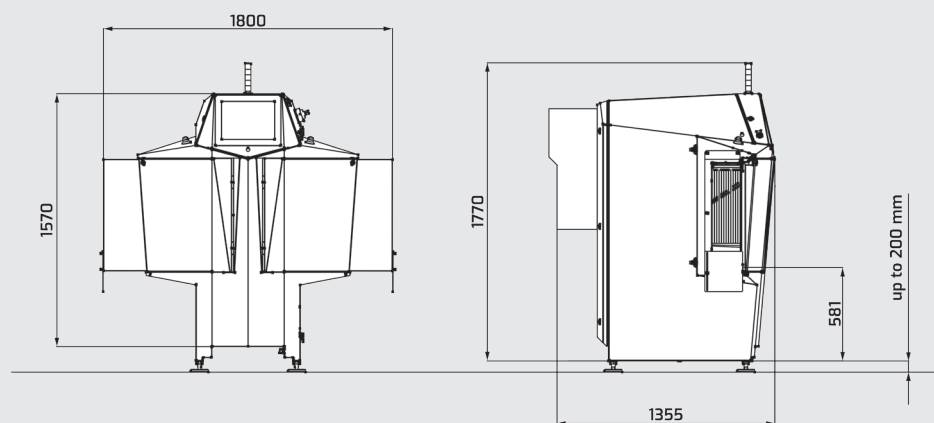

BEAM GEOMETRY

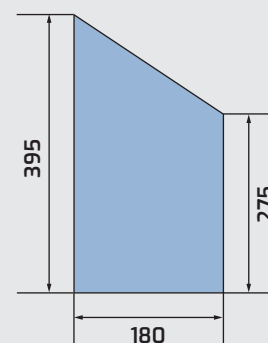

Subject to modifications and improvements.

DYLOG[®]
HITECH

Dylog Hitech Srl

C.so Bramante, 53 - Torino - Italy - Tel. +39 011 6938406

hitechsales@dylog.it - www.dyloghitech.com



Company with management system certified
UNI EN ISO 9001:2015