

Food X-ray Inspection

DYLOG[®]
H I T E C H

DYLIGHT S



DYLIGHT SIDE VIEW MACHINE

The use of advanced components and an attentive, innovative and compact design, together with a high-performance and intuitive software allows Dylight machines to be fit for the ever higher standards set by food and pharmaceutical companies.

ADVANTAGES OF X-RAY INSPECTION

This is a **non-destructive analysis**, which, without altering the chemical composition or the organoleptic properties of the products, detects contaminants inside them (in any type of container or package) and verifies their wholeness and conformity. Contaminants having a density higher than the density of the inspected products (metals, glass, highly calcified bones, stones, shells, ceramics, PVC, Viton®) will no longer be a problem.



X-RAY POWER

100 W

POINT OF VIEW

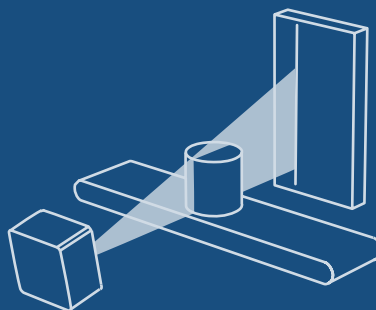

PRODUCTS



Hardware

An entry-level inspection system, **affordable and performing**, with all the essential technical solutions, that can be easily installed on existing straight conveyors. The Dylight S **can be installed on an existing straight conveyor**, with a quick and simple alignment procedure, thanks to the new numbered reference lines system.

Thanks to an innovative design philosophy, **all the main components are accessible and replaceable with ease**, as all internal surfaces are accessible and washable.

Perfect for brickpack, metal or paper can and plastic bottles inspection.

The **air cooling system** allows the machine to work in a wide range of temperature, without the need of an external water cooling system normally used with more powerful machines.

With the Dylight S, Dylog can offer **a really plug&play inspection solution** for products in rigid containers, keeping nonetheless top-notch performance levels.

Software

The Dylog contaminant detection software ensures a high performance level; thanks to new filtering technology and parallel elaboration, **the X-ray images are almost noiseless** with a high contrast level even at high product speed.

The innovative hardware design is coupled with an entirely new software interface for the Dylight S, that combines user friendliness with a complete set of functions, the result of over 20 years of experience in the food and pharmaceutical industries.

Sophisticated algorithms constantly refined provide excellent performances even when compared higher power systems.

The machine can be controlled from remote and features a 5-level password security system allowing to track the activity of each operator, logging in with a unique password.

Production and usage data are redundantly stored to grant top-notch level security, while the data accessibility is granted by easy to read automatic reports.

The system is **compatible with the strictest control protocols** implemented by the food industry largest companies.

Technical Features

Power	100 W
Detector resolution	0.8 mm
Conveyor belt speed	Up to 50 m/min
Conveyor height	850–1100 mm
Minimum distance between products	10 mm
Curtains	Unleaded FDA approved
Safety switches / interlock	SIL 3 Category IV PLe, magnetic
HMI	15" LCD – touch screen
Operating temperature	5–35 °C
Relative humidity	20%–90% (non condensing)
Power supply	230 VAC ±10% (standard)
Compressed air	5.5–6.9 bar
Cooling	Air fans or air conditioner Nema 4X 300 W
Radiation protection	FDA CFR 21 part 1020.40
International Protection Rating (IP)	IP54 with air fans / Nema 4X with air conditioner
Connectivity Options	Ethernet available with communication protocols: Modbus TCP (standard), OPC-DA, OPC-UA, XML messages on TCP, others on request
Production data trail	Complete records on parameters, users and products

Dimensions

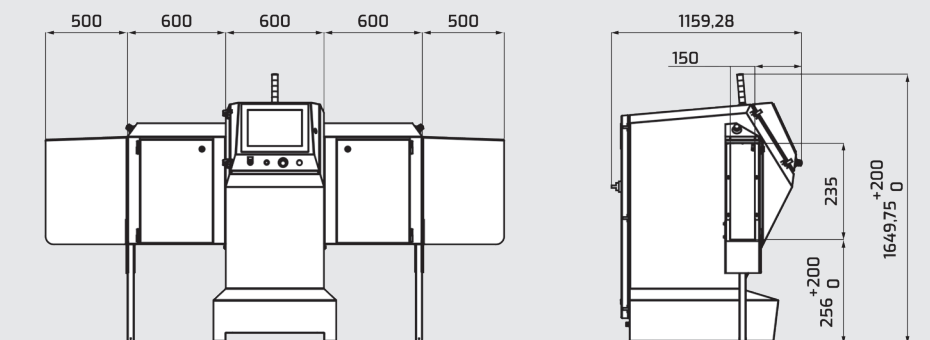

BEAM GEOMETRY

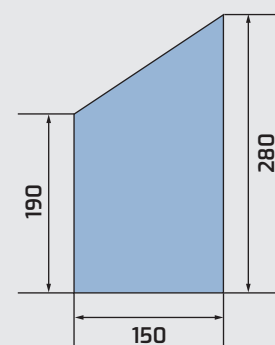

Subject to modifications and improvements.

DYLOG[®]
HITECH

Dylog Hitech Srl

C.so Bramante, 53 - Torino - Italy - Tel. +39 011 6938406

hitechsales@dylog.it - www.dyloghitech.com



Company with management system certified UNI EN ISO 9001:2015