

ACCUWEIGH ABOVE GROUND WEIGHBRIDGES

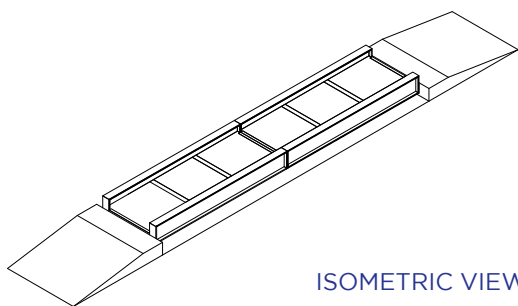

ISOMETRIC VIEW



Chain of Responsibility
Solutions Providers

FEATURES

- Steel Cross-Sections at Approximately 3m Spacings
- Designed for Minimal Concrete Cracking
- Engineering Report on Design Available
- Designed for Long-Term Performance
- Available in Standard 3m or 3.5m Widths
- Custom Widths Available
- Available in Kit Form, If Required
- Fully Hot-Dipped Galvanised

ACCUWEIGH



BY DIVERSECO

Australian-made, high-quality,
and precise weighing solutions.

- Australia's Largest Weighbridge Supplier - 100+ Weighbridges Sold Each Year
- A True National Company with Branches and Service Centres in All States
- 100% Australian-Owned and Operated Company, Profits Stay in Australia

- ISO 9001 Company Ensuring a Quality Product and Professional Service
- Experienced Weighbridge Service Crews in All States
- Trade-Approved, Designed for Australia's Harsh Environment
- Proven Design Over Many Installations

DESIGNS FORMATS

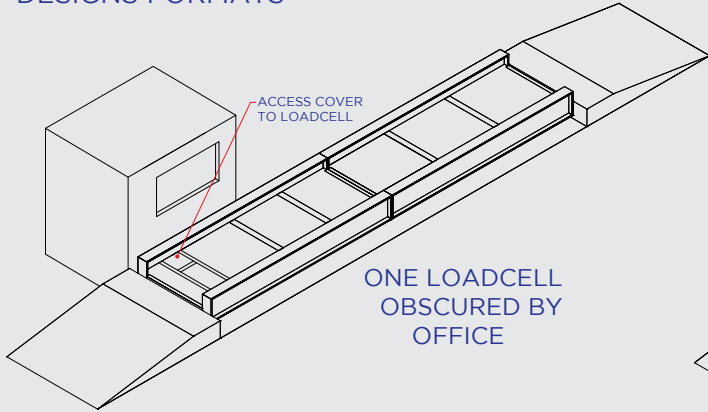

ONE LOADCELL
OBSCURED BY
OFFICE

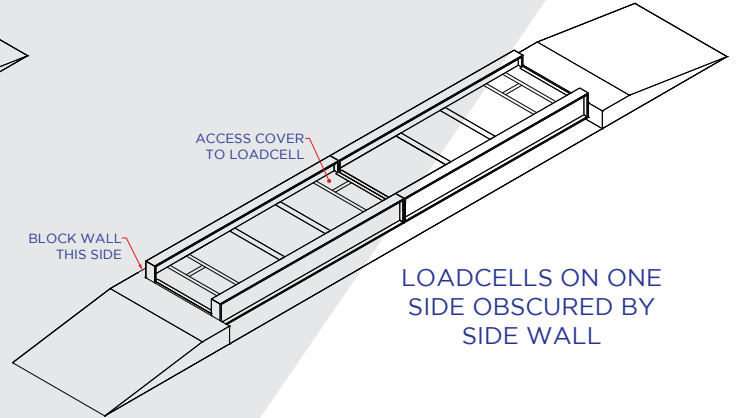

LOADCELLS ON ONE
SIDE OBSCURED BY
SIDE WALL

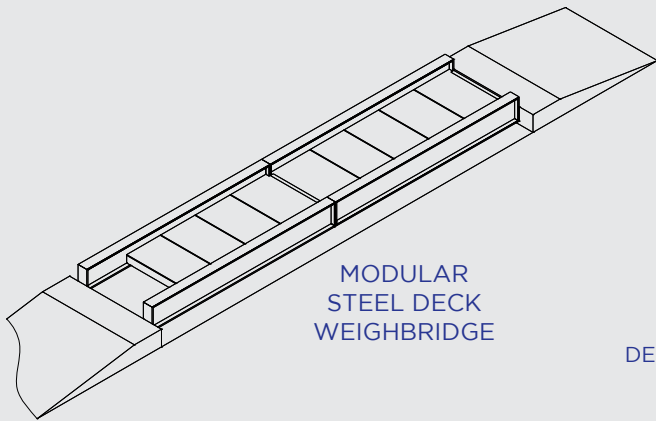

MODULAR
STEEL DECK
WEIGHBRIDGE

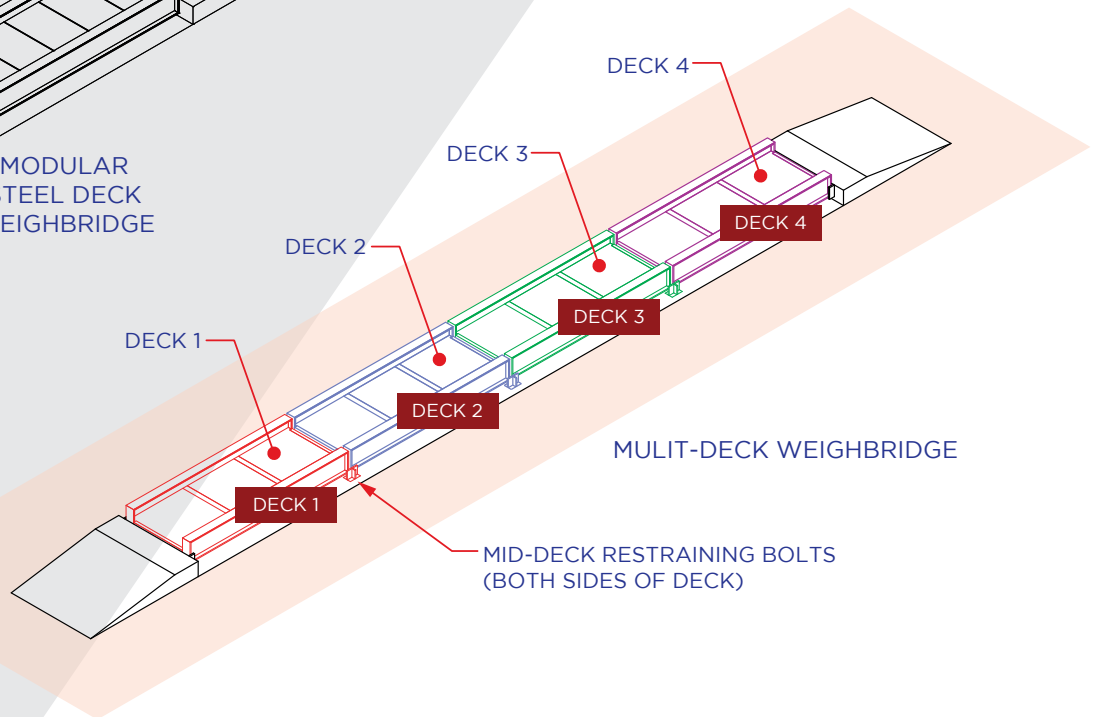

MULTI-DECK WEIGHBRIDGE

All Branches T: 1300 069 970
 NSW (Sydney) T: (02) 9728 4877
 VIC (Melbourne South) T: (03) 9548 5512
 VIC (Melbourne North) T: (03) 9357 7470
 QLD (Brisbane North & South) T: (07) 3265 5520
 WA (Perth) T: (08) 9259 5535
 SA (Adelaide) T: (08) 8447 5011
 New Zealand (Auckland) T: +64 9 951 9685

diverseco.com.au