



Dual interval technology



Rear display option



Battery operation

SW SERIES

Smart Weighing Scales

Compact Design and easy to use, suitable for multipurpose environments where light weight & portable scales are needed.

- **Trade Approved* (NMI No. 6/4C/260)**
*exc. Counting Function (SW-1C).
- Dust & Waterproof (SW-1W)
- Counting & Limit Function (SW-1C)
- Battery Operation
- 25mm LCD Display
- Dual Interval



SW-1W | Waterproof Weighing Scale



SPECIFICATIONS

Model	SW-1W		
Max. Capacity (kg)	4/10	10/20	15/30
Readability (g)	2/5	5/10	5/10
Max. Tare (kg)	-3.998	-9.995	-14.995
Internal Resolution	1/60,000		
External Resolution	1/2,000 ~ 1/3,000 (Dual Interval)		
Display Digit	5 Digits		
Display Type	LCD		
Operating Temp.	-10°C ~ 40°C		
Power	Dry Battery (6 x D type), 9V DC Adapter		
Battery Life	Approx. 400hrs or 800hrs (Alkaline battery)		
Platter Size (mm)	247(W) x 195(D)		
Dimensions (mm)	278(W) x 317(D) x 141(H)		
Product Weight (kg)	3.7		

1/2,000~1/3,000 dual interval resolution for better accuracy

The SW-1W adopts dual interval technology, allowing for an automatic change of the SW-1W interval for an even more precise reading.



Dust & Waterproof digital scale (Level IP 66)

The SW-1W is protected from water, dirt and other external agents.



Clear and Highly legible LCD displays

SW-1W Series has a 25mm large LCD display and uses 5 highly legible digits.



Used anywhere with battery power

SW Series is operated by an AC adapter or alkaline batteries.

Its compact design is great for use anywhere.



DIMENSIONS

SW-1W

Unit: mm

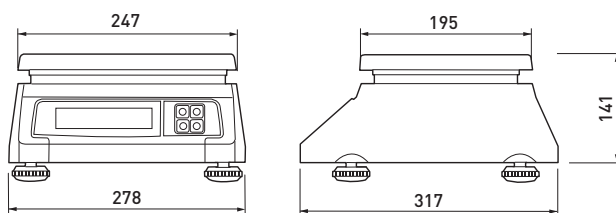

OPTIONS

- 9V DC adapter



Adapter can be different for each country

SW-1C | Counting Scale



SPECIFICATIONS

Model	SW-1C				
Max. Capacity (kg)	1/2	2.5/5	4/10	10/20	15/30
Readability (g)	0.5/1	1/2	2/5	5/10	5/10
Max. Tare (kg)	-0.9995	-2.499	-3.998	-9.995	-14.995
Internal Resolution	1/60,000				
External Resolution	1/2,000 ~ 1/3,000 (Dual Interval)				
Display Digit	5 Digits				
Display Type	LCD				
Operating Temp.	-10°C ~ 40°C				
Power	Dry Battery (6 x D type), 9V DC Adapter				
Battery Life	Approx. 400hrs or 800hrs (Alkaline battery)				
Platter Size (mm)	230(W) x 190(D)				
Dimensions (mm)	260(W) x 287(D) x 137(H)				
Product Weight (kg)	2.8				

1/2,000~1/3,000 dual interval resolution for better accuracy

The SW-1W adopts dual interval technology, allowing for an automatic change of the SW-1C interval for an even more precise reading.



Clear and Highly legible LCD displays

SW-1C Series has a 25mm large LCD display and uses 5 highly legible digits. Also features a Rear Display for clients to view.



Accurate counting function (SW-1C only)

The SW-1C has a simple counting and limit function for quality product management. It is great for use in manufacturing, parts shops, hardware stores etc.

(Non-Trade Use.)



Used anywhere with battery power

SW Series is operated by an AC adapter or alkaline batteries.

Its compact design is great for use anywhere.



DIMENSIONS

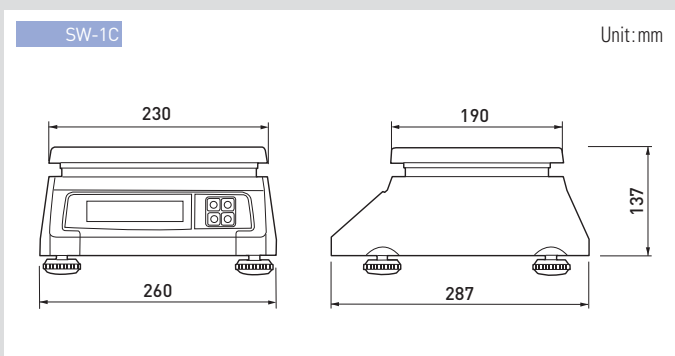

FEATURES

- Dust protection cover



Scoop Platter

OPTIONS

- AC adapter (9V/300mA)
- Stainless Steel Platter
- Scoop Platter



Stainless steel platter



WE WEIGH THE WORLD™

