



Unit Conversion: lb, oz



Dual Interval



Battery Operated

PW-II SERIES

Portion Control Scale

Compact in design and easy to use portion control scale for use in a variety of applications. Simple stainless steel construction. AC or battery operated. Use in restaurants, specialty stores, farmer's markets and more!

- Stainless Steel Construction
- Unit Selection: kg, g, lb, oz
- Dry Battery Operated (6 x AA)
- Dual Interval



PW-II SERIES | Portion Control Scale

SPECIFICATIONS

Model	PW-II		
Max. Capacity (kg)	1/2	2.5/5	4/10
Readability (g)	0.5/1	1/2	2/5
Internal Resolution	1/60,000		
External Resolution	1/2,000 ~ 1/2,500 (Dual Interval)		
Display Digit	5 Digits		
Display Type	LCD		
Operating Temp.	-10°C~40°C		
Power	Dry Battery (6 x AA), 9V DC Adapter (option)		
Battery Life	Alkaline: 250hrs, Min: 60hrs		
Platter Size (mm)	222(W) x 151(D)		
Dimensions (mm)	239(W) x 227(D) x 66(H)		
Product Weight	1.7 kg		

FEATURES

- Simple weighing scale
- Stainless Steel body & tray
- Soft touch tact switch
- Simple and easy operation
- LCD Display
- Battery operated
- Auto Calibration
- kg, g, lb, oz Convertible
- Low Battery indication
- Function Key: On/Off, Zero, Tare, Unit/Hold

OPTIONS

- Hold or Unit version
- AC Adapter

DIMENSIONS

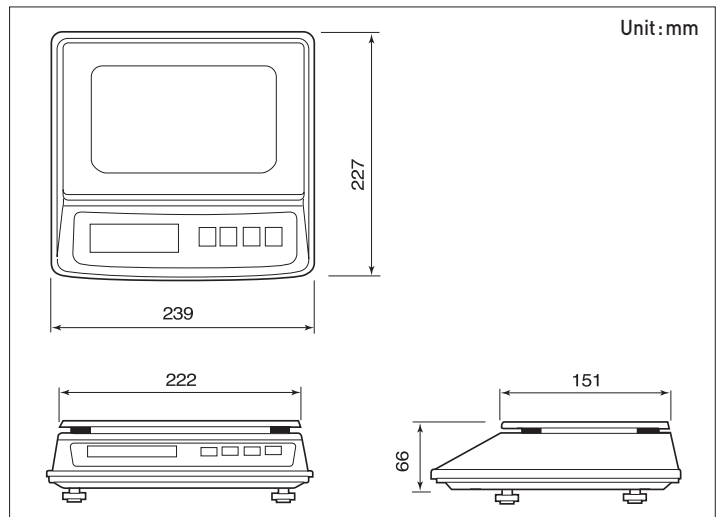

DISPLAY & KEYPAD

- Hold or Unit version

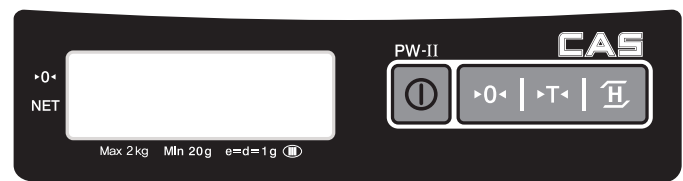

CAS

UNIT 8, NORTHLINK, 459 TUFNELL ROAD
BANYO QLD 4014, AUSTRALIA

TEL: +61 (0)7 3267 7767 FAX: +61 (0)7 32 67 1818

EMAIL: sales@cassscale.com.au

<http://www.cassscale.com.au>

Specifications are subject to change for improvement without prior notice.